





9 Extractores

code	pag.
462.012	194
	
462.150	195
	

code	pag.
462.352	195
	
462.417	196
	

code	pag.
463.627	197
	
464.400	197
	

code	pag.
464.205	197
	

462 Extractor Universal de 2 Garras

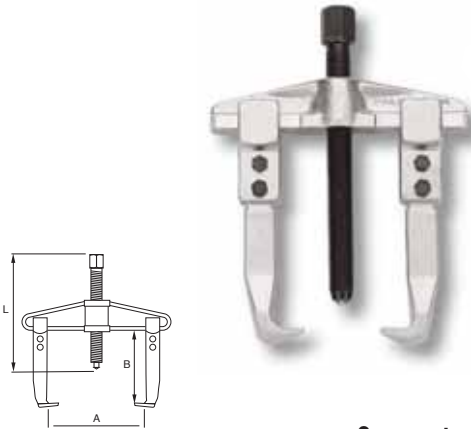

Garras extensibles y reversibles

Garra corta

UNE 16597

CODE	A		B mm	L mm	Pot Tn	GRS./U.	☐	€/U.
	MIN	MAX						
462.010	50	80	100	135	4	1.040	1	71,43
462.012	50	120	100	135	4	1.140	1	74,76
462.014	80	160	150	205	8	3.000	1	124,24
462.016	90	200	150	205	8	3.275	1	128,52
462.018	110	250	200	270	13	7.400	1	206,70
462.024	120	350	200	270	13	8.200	1	222,77

Accesorio:



Garra Larga

CODE extractor	CODE garra larga	€/U.
462.010	462.040	27,64
462.012	462.040	27,64
462.014	462.042	38,45
462.016	462.042	38,45
462.018	462.044	60,19
462.024	462.044	60,19



Repuestos

CODE extractor	CODE garra corta	€/U.	CODE husillo ¹	€/U.	CODE husillo ²	€/U.
462.010	462.030	21,96	462.090	17,88	462.090	17,88
462.012	462.030	21,96	462.090	17,88	462.090	17,88
462.014	462.032	31,49	462.091	24,42	462.191	24,44
462.016	462.032	31,49	462.091	24,42	462.191	24,44
462.018	462.034	48,41	462.092	46,59		
462.024	462.034	48,41	462.092	46,59		

- 1) Para extractores fabricados antes del 2007.
- 2) Para extractores fabricados a partir del 2007.

462 Extractor de 2 Garras Reversibles

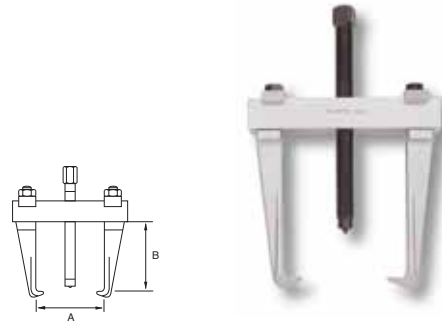

UNE 16597

CODE	A mm		B mm	Pot Tn	GRS./U.	☐	€/U.
	MIN	MAX					
462.008	15	80	80	2	925	1	83,33
462.011	15	80	135	2	1.090	1	91,04
462.007	15	125	80	2	1.100	1	93,71
462.009	15	125	135	2	1.300	1	103,03
462.013	25	150	160	10	3.180	1	171,36
462.015	25	145	220	10	3.870	1	194,92
462.017	30	195	220	10	4.375	1	222,77
462.020	70	250	260	20	10.200	1	355,57

Repuestos

CODE extractor	CODE garra	€/U.	CODE husillo	€/U.
462.007	462.031	33,56	462.070	18,42
462.008	462.031	33,56	462.070	18,42
462.009	462.041	38,35	462.071	21,32
462.011	462.041	38,35	462.071	21,32
462.013	462.033	52,73	462.072	39,84
462.015	462.043	67,93	462.073	56,23
462.017	462.043	67,93	462.073	56,23
462.020	462.035	99,04	462.074	86,11

462 Extractor de 2 Patas

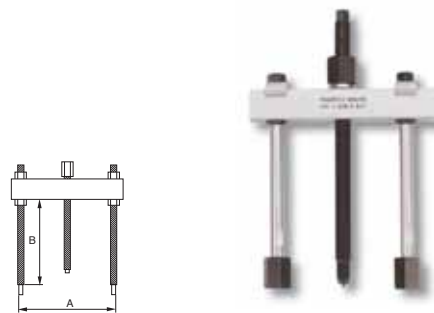

CODE	A		B mm	Rosca Amarre	Pot Tn	GRS./U.	☐	€/U.
	MIN	MAX						
462.110	40	90	120	3/8	2	940	1	81,83
462.114	50	170	205	5/8	10	3.300	1	197,06
462.119	85	265	255	5/8	20	9.700	1	390,92

Repuestos

CODE extractor	CODE garra	€/U.	CODE husillo	€/U.
462.110	462.036	18,74	462.071	21,32
462.114	462.037	45,95	462.075	48,20
462.119	462.038	80,00	462.076	91,04



462 Separador de Guillotina

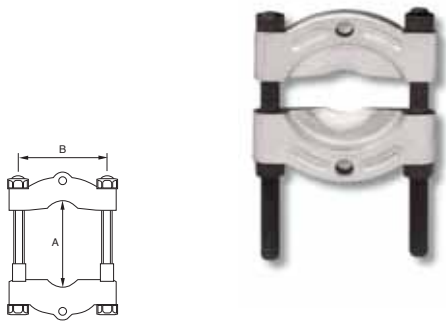

CODE	A		B mm	Rosca Amarre	GRS./U.	📦	€/U.
	MIN	MAX					
462.148	5	50	60	3/8	725	1	77,65
462.150	10	110	110	5/8	2.660	1	139,23
462.152	10	130	150	5/8	5.760	1	283,82

Repuestos

CODE extractor	CODE husillo	€/U.
462.148	462.077	13,49
462.150	462.078	31,27
462.152	462.079	45,84

462 Extractor de 2 Garras Oscilantes de Doble Posición

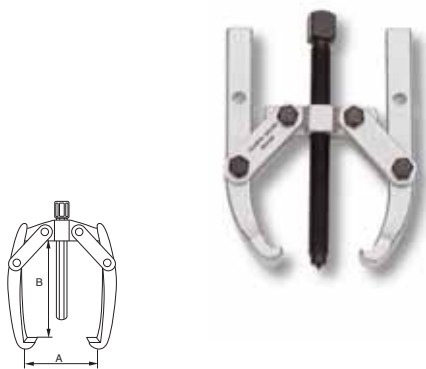

UNE 16580

CODE	A Máx. mm	B Máx. mm	Pot Tn	GRS./U.	📦	€/U.
462.205	70	55	0,5	200	1	38,13
462.210	100	85	1	390	1	48,09
462.213	150	135	4	1.130	1	72,72

Repuestos

CODE extractor	CODE garra	€/U.	CODE husillo	€/U.
462.205	462.050	9,05	462.080	11,25
462.210	462.051	11,57	462.081	14,13
462.213	462.052	19,81	462.082	24,31
462.215	462.053	25,38	462.083	38,23
462.220	462.054	91,36	462.073	56,23

462 Extractor de 3 Garras Oscilantes de Doble Posición

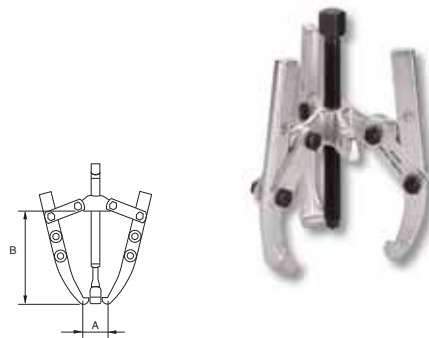

UNE 16580

CODE	A Máx. mm	B Máx. mm	Pot Tn	GRS./U.	📦	€/U.
462.245	70	55	0,5	280	1	55,37
462.250	100	85	1	625	1	72,62
462.253	150	135	4	1.750	1	111,38
462.255	200	180	7	3.590	1	157,44
462.260	310	300	10	7.250	1	340,58
462.265	425	365	17	16.200	1	576,20

Repuestos

CODE extractor	CODE garra	€/U.	CODE husillo	€/U.
462.245	462.050	9,05	462.080	11,25
462.250	462.051	11,57	462.081	14,13
462.253	462.052	19,81	462.082	24,31
462.255	462.053	25,38	462.083	38,23
462.260	462.054	91,36	462.073	56,23
462.265	462.055	117,81	462.074	86,11

462 Extractor de 3 Garras Oscilantes Dobles Reversibles

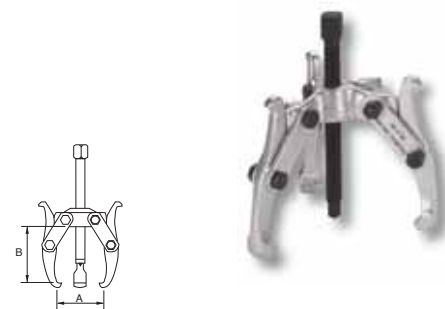

UNE 16580

CODE	A Máx. mm	B Máx. mm	Pot Tn	GRS./U.	📦	€/U.
462.350	80	67	1	580	1	76,04
462.352	150	85	4	1.450	1	98,64
462.355	200	125	7	3.050	1	157,44
462.360	320	260	10	6.800	1	327,73

Repuestos

CODE extractor	CODE garra	€/U.	CODE husillo	€/U.
462.350	462.056	10,61	462.081	14,13
462.352	462.057	16,28	462.082	24,31
462.355	462.058	29,78	462.083	38,23
462.360			462.073	56,23



462 Extractor de Garras Múltiples

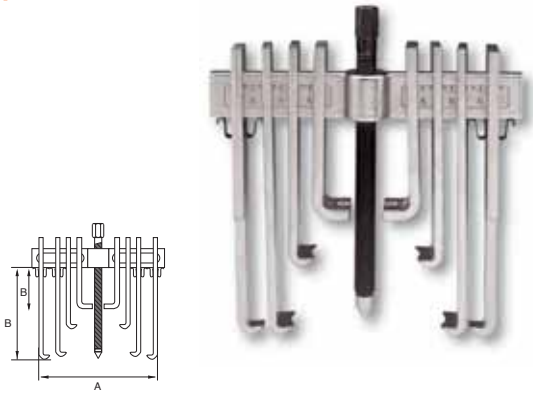

CODE	A		B mm	Pot Tn	GRS./U.	📦	€/U.
	MIN	MAX					
462.415	30	170	B ¹ /140 B ² /140 B ³ /100 B ⁴ /65	5	2.630	1	170,29

Garras de Recambio

B-1 B-2 B-3 B-4



CODE	MOD.	LONG. Boca			📦	€/U.
		Curva	Cóncava	Recta		
462.434	B-4	65	—	—	1	17,24
462.435	B-3	100	—	—	1	15,86
462.436	B-2	—	140	—	1	15,86
462.437	B-1	—	—	140	1	17,24

Husillo de Recambio

CODE extractor	CODE husillo	€/U.
462.415	462.084	25,17

462 Extractor de Garras Múltiples

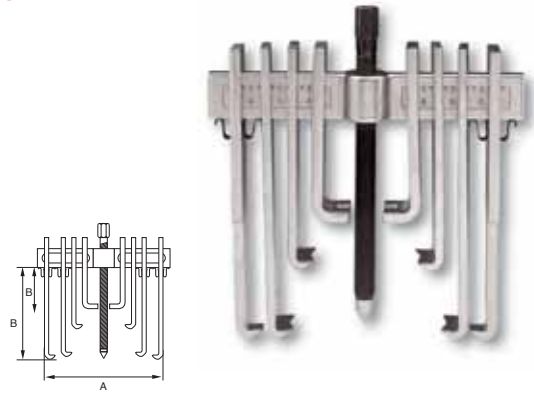

CODE	A		B mm	Pot Tn	GRS./U.	📦	€/U.
	MIN	MAX					
462.417	75	250	B ¹ /180 B ² /180 B ³ /122 B ⁴ /77	10	5.800	1	251,69

Garras de Recambio

B-1 B-2 B-3 B-4



CODE	MOD.	LONG. Boca			📦	€/U.
		Curva	Cóncava	Recta		
462.424	B-4	77	—	—	1	22,17
462.425	B-3	122	—	—	1	22,17
462.426	B-2	—	180	—	1	23,56
462.427	B-1	—	—	180	1	23,56

Husillo de Recambio

CODE extractor	CODE husillo	€/U.
462.417	462.085	32,88

462 Juego de Extractores Mini



CODE	Nº Piezas	GRS.	📦	€/U.
462.900	6	1.320	1	186,35

Nº Pzas.	COMPOSICIÓN
1	Extractor 2 garras oscilantes de doble posición 70 x 55
1	Extractor 2 garras oscilantes de doble posición 100 x 85
1	Cuerpo para extractor de 3 garras oscilantes de doble posición 70 x 55
1	Cuerpo para extractor de 2 y 3 garras oscilantes de doble posición 100 x 85
1	Pata para extractor de 2 y 3 garras oscilantes de doble posición 70 x 55
1	Pata para extractor de 2 y 3 garras oscilantes de doble posición 100 x 85



463 Juego de Extractores de Tornillos Rotos



CODE	Nº Piezas	GRS.		€/U.
463.204	4	300	1	85,68

COMPOSICIÓN

Extractores M5 - M10, M8 - M14, M12 - M20 y M16 - M24

463 Juego de Extractores de Tornillos Rotos



CODE	Nº Piezas	GRS.		€/U.
463.305	25	630	1	114,60

Nº Pzas. COMPOSICIÓN

5	Brocas HSS de Ø 4, 5, 6, 7'5 y 8'5 mm.
5	Extractores estriados de Ø 4, 5, 6, 7'5 y 8'5 mm.
5	Tuercas de extracción de Ø 4, 5, 6, 7'5 y 8'5 mm.
4	Guías de taladro de Ø 4 para Métrica 5, 6, 7 y 8.
3	Guía de taladro de Ø 5 para Métrica 8, 9 y 10.
1	Guía de taladro de Ø 6 para Métrica 11.
1	Guía de taladro de Ø 7'5 para Métrica 12.
1	Guía de taladro de Ø 8'5 para Métrica 14.

UTILIZACIÓN DE EXTRACTORES PARA TORNILLOS ROTOS

1. Taladrar el tornillo con el Ø de broca que corresponda.
2. Introducir el extractor con un golpe de martillo.
3. Aproximar la tuerca de extracción al tornillo roto.
4. Con una llave, girar el extractor en el sentido contrario a la rosca.
5. Importante aplicar productos "Aflojatodo".

462 Extractores para Rodamientos



CODE	Nº Piezas	GRS.		€/U.
462.910	25	1.315	1	463,74

Para rodamientos del 6000 al 6006 - del 6200 al 6205 - del 6300 al 6303

463 Tronzatuercas



CODE	mm	A	L	GRS.		€/U.
463.627	6 a 27	32	126	0,180	1	38,23
463.636	6 a 36	40	170	0,300	1	106,35

Repuestos

CODE tronzatuercas	CODE cuchilla	€/U.	CODE husillo	€/U.
463.627	463.648	7,34	463.647	7,12
463.636	463.645	40,16	463.646	26,88

464 Palanca Universal

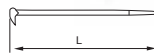

CODE	L mm	GRS.		€/U.
464.400	400	480	1	35,13

464 Volvedores

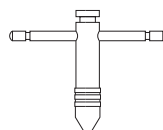

CODE	mm	L	GRS./U.		€/U.
464.205	2,6 5,5	85	180	1	20,55
464.208	4,6 8	110	300	1	26,71



